

DEVELOPMENT OF DRIVING CYCLES FOR DYNAMOMETER CONTROL SOFTWARE CORRESPONDING TO PECULIARITIES OF LATVIA

Ilmars Dukulis, Vilnis Pirs

Latvia University of Agriculture

e-mail: ilmars.dukulis@llu.lv, vilnis.pirs@llu.lv

Abstract

Performing biofuel use studies, a large number of parameters that characterize engine operation under different conditions and with different fuel mixtures have to be identified. The real driving conditions are usually simulated by driving cycles on a laboratory chassis dynamometer. There are two major categories of driving cycles: legislative and non-legislative. From the viewpoint of cycle formation there are also two ways. One is composed of various driving modes of constant acceleration, deceleration and speed, and is referred to as modal or polygonal. The other type is derived from actual driving data and is called as 'real world' cycle. There is a strong agreement among researchers that driving characteristics of each city are unique because of different vehicle fleet composition, driving behaviour and road network topography. It is therefore better to develop own driving cycles than using driving cycles developed elsewhere. The aim of this investigation is to develop driving cycles or models for dynamometer control software corresponding to peculiarities of Latvia. The procedure for cycle development and fuel consumption and exhaust emissions measurement was worked out. Using real driving data on the Jelgava streets, models simulating driving in different urban areas were constructed. The model quality was determined using vehicle driving parameters and fuel consumption measurement results from both the road and laboratory tests. Since the obtained data coincidence of all the parameters exceeded 98%, the elaborated cycles can be used for the biofuel use efficiency determination.

Key words: driving cycles, laboratory chassis dynamometer, exhaust emissions, fuel consumption.

Introduction

During the pilot studies on the biofuel use level, it is necessary to identify a large number of parameters that characterize engine operation under different conditions, with different fuel mixtures, etc. If the methods of power, torque, acceleration, etc. detection are particularly developed, the fuel consumption and exhaust gas composition determination is often a problem. Potential users of biofuel are less satisfied with the results found in the analytical experiments, for example, by running the

engine on the test bench. The more relevant is to know the parameters that would be expected in real operating conditions, therefore it is very important to work out the methodology of the synthetic experiments to draw them nearer to the real urban traffic, driving outside the city or the combined mode.

The typical driving profile consists of a complicated series of accelerations, decelerations and frequent stops and it is simulated by driving cycles on a laboratory chassis dynamometer, for example, MD-1750 (Figure 1).

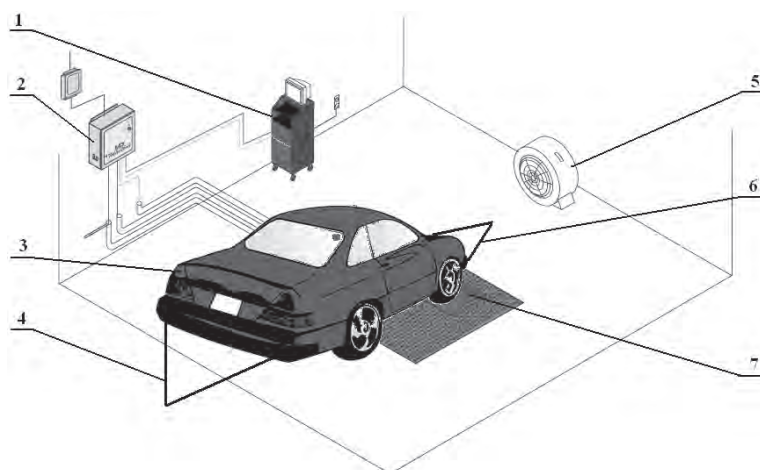

Figure 1. Laboratory chassis dynamometer MD-1750: 1, 2 – control units; 3 – car; 4, 6 – safety belts; 5 – fan; 7 – dynamometer.

There are two major categories of driving cycles: legislative and non-legislative. According to legislative driving cycles, Exhaust Emission Specifications are imposed by governments for the car Emission Certification. Such cycles are the FTP-75 used in the USA, the NEDC used in Europe, and the 10-15 Mode Cycle used in Japan (Emission Test Cycles, 2008). Non-legislative cycles, such as the Edinburgh cycle (Esteves-Booth et al., 2001), the Hong Kong driving cycle (Hung et al., 2007), the Athens driving cycle (Tzirakis et al., 2006), the California driving cycle (Lin and Niemeier, 2002), etc. find broad application in research for fuel consumption and pollution evaluation.

The directive 80/1268/EEC relating to the carbon dioxide emissions and the fuel consumption of motor vehicles, describes the procedure that all new types of vehicles have to follow. The driving cycle used by the EU countries for the certification of passenger cars and light trucks, consists of four segments of ECE-15 (also known as Urban Driving Cycle) and the Extra Urban Driving Cycle (EUDC). The procedure is called New European Driving Cycle (NEDC). Urban Driving Cycle is representative of city driving conditions in a typical European city (for example, Paris and Rome). Extra Urban Driving Cycle simulates high speed driving and is applied directly after the fourth segment of ECE-15 (Figure 2) (Emission Test Cycles, 2008).

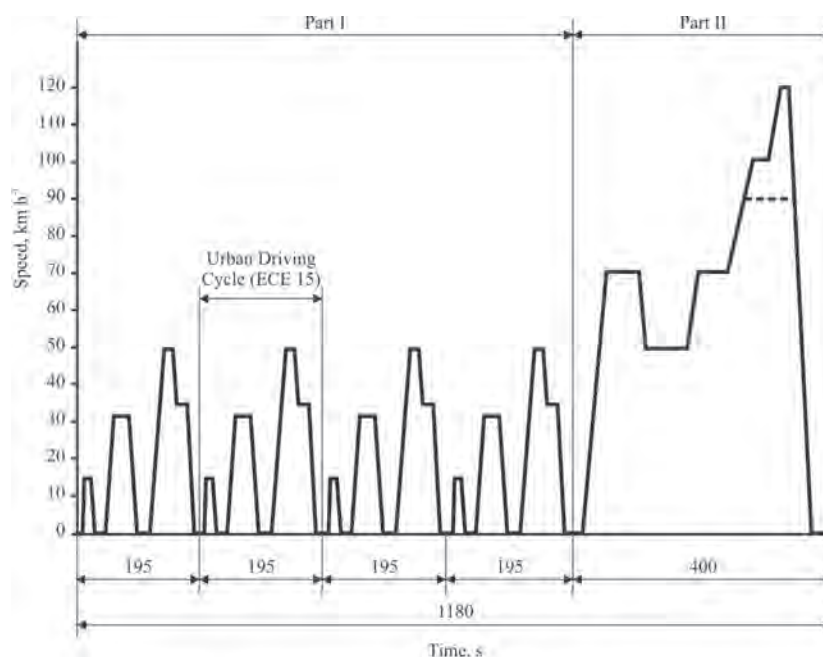

Figure 2. New European Driving Cycle.

There are two ways of developing a driving cycle. One is composed of various driving modes of constant acceleration, deceleration and speed, for example, NEDC, and is referred to as modal or polygonal. The other type is derived from actual driving data and is referred to as 'real world' cycle. Such cycle examples are the FTP-75 and the Athens driving cycle. The 'real world' cycles are more dynamic, reflecting the more rapid acceleration and deceleration patterns experienced during on road conditions. It results in higher emissions compared to those under the modal test cycles (Tzirakis et al., 2006).

There is a strong agreement among researchers that driving characteristics of each city are unique because of different vehicle fleet composition, driving behaviour and road network topography (Andre et al., 2006). It is therefore better for environmental

protection administrations to congregate all the distinct information to develop their own driving cycles than using driving cycles developed elsewhere. A practical driving cycle construction method comprises three major components – namely data collection methodology, test route selection methodology, and the cycle construction methodology.

Many driving cycles have been developed worldwide. The FTP-72 and FTP-75 cycles were developed by choosing the whole test run data with the most representative speed-time profile based on the idle time, average speed, maximum speed, and number of stops per trip. One of the earliest European driving cycles was the Improved Driving Cycle (IMC) developed by using ten assessment parameters, including the average speed, average running speed, average acceleration

and deceleration, mean length of micro-trips, average number of acceleration-deceleration changes within one micro-trip, and proportions of idling, acceleration, cruising and deceleration (Kuhler and Karsten, 1978). The UK fuel consumption cycle was developed by random simulation of the speed against time as the function of the distributions of the operational modes. The Edinburgh cycle was developed by the TRAFIX method, which generated specific codes for each driving segment (Esteves-Booth et al., 2001). The German motorway driving cycle was derived using the Monte Carlo statistical method, simulating acceleration from speed-time profile as a function of the cumulative speed acceleration distribution.

The laboratory chassis dynamometer MD-1750 used in the experiments at the Scientific Laboratory of Biofuels (Latvia University of Agriculture) includes Mustang's MD-7000 software package. Supported tests are the IM-240, FTP, 505 MT, BAR 31 Int., ECE 1504 A/M, and Japanese 10/11.

Performing tests under the real road conditions of Latvia and comparing the obtained results with the available cycle parameters (cycle duration, average micro-trip length, average micro-trip duration, stops per kilometre, proportion of acceleration and deceleration, average and maximum running speed, etc.), they were very different, especially driving in urban areas. Consequently, the need to develop the driving cycles, which would be applied directly to Latvia, arose. Development of the urban cycles have to be done first, because the different incidental factors (for example, traffic intensity and traffic

light setting changes, unexpected barriers on the streets, etc.) more often occur in the city driving.

Summarizing literature studies, the following tasks were set for this investigation:

- identification of approximate number of different necessary urban cycles for Latvia;
- selection of the specific city driving routes;
- development of the real driving imitation (model) for the laboratory chassis dynamometer;
- performing the model quality verification;
- setting up the targets for further investigations.

Materials and Methods

Based on the Eurostat document 'Nomenclature of Territorial Statistical Units' (NUTS) (European Regional and Urban Statistics, 2007) and analyzing the urban population, the street network, the existence of traffic lights, etc. parameters in the cities of Latvia, it was assumed that in the cycle creation cities can be divided into three categories: the capital of Latvia – Riga, the large cities (for example, Daugavpils, Jelgava, Liepaja), and the small cities (for example, Aluksne, Gulbene, Smiltene). In addition, separate research is needed for the cities centre or core (intensive driving with the traffic lights), for the widened centre (with and without the traffic lights), and for the more widened urban area with segments where driving speed more than 50 km h⁻¹ is allowed. The 'real world' cycle development method was chosen. The flow chart of the procedure for the cycle development and the emission and fuel consumption measurement is shown in Figure 3.

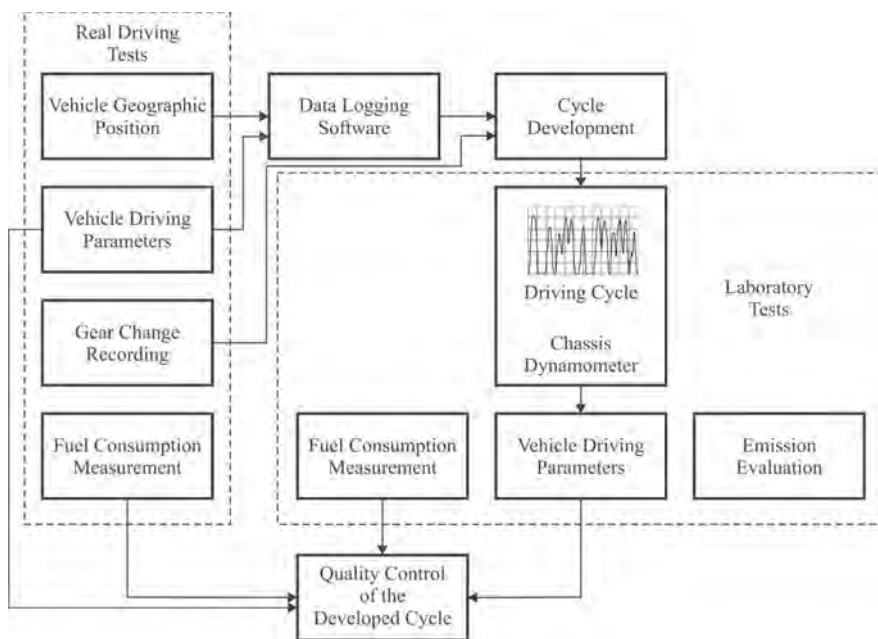

Figure 3. Flow chart of the procedure for cycle development and measurement.

A VW Golf 1.9TD was employed as the chase instrumented vehicle in this study. It was installed with the following equipment:

- data logger CANYON CNS-GPS2 for determination of the GPS (Global Positioning System) coordinates and driving speed;
- camcorder DCR-SR30E for fixing the route and gear switching time;
- fuel consumption meter AVL KMA Mobile;
- laptop for recording GPS and fuel consumption signals.

As the first city for experiments Jelgava was chosen. A total of 10 h of data were collected with the car chasing technique along three selected representative routes (Figure 4) during the peak hours (8:00–9:30 and 11:30–13:30). Driving tests were conducted only during normal working days, excluding the public holidays.



Figure 4. Driving routes in Jelgava.

Processing of the data collected from the data logger and the fuel consumption meter proved to be very time-consuming due to the variable field separation format and a lot of unnecessary information between data records,

especially considering the large number of repetitions for each test series. As an example the fuel consumption meter data format is shown in Figure 5.

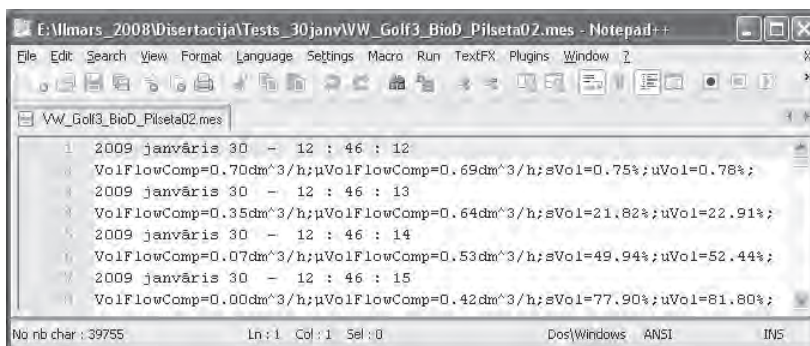

Figure 5. Obtained data format from AVL KMA Mobile.

Solving this problem several macroses were programmed by using of Visual Basic for Applications that allows quickly to import data into the spreadsheet application.

In the first route, 15 drive repetitions were made. Three trips with the highest speed curves correlations were selected for model building (Figure 6, Table 1).

For each trip second, an average speed was calculated. Extreme phases were removed such as very high top speed phases, and minor adjustments to speed curves displacement were made. As the result a theoretical velocity curve for 360 second cycle was built. Gear switching moments were determined by video cameras records (Figure 7).

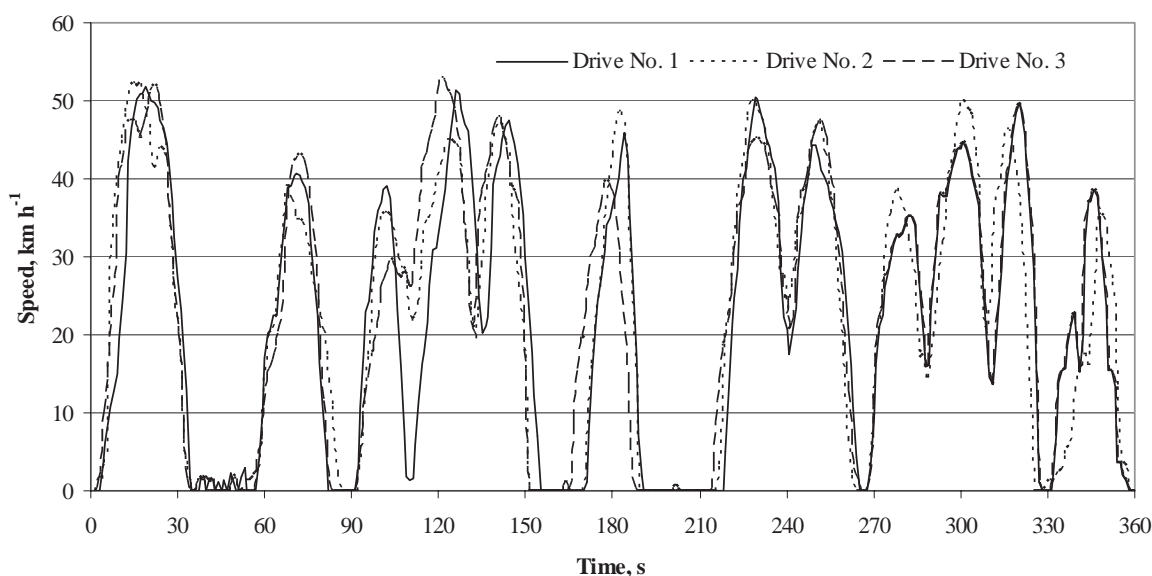

Figure 6. Velocity curves of test drives.

Table 1

Analysis of test drives

Drive No.	Time, s	Distance, km	Average speed, km h ⁻¹	Correlation of velocity curves		
				1	2	3
1	366	2.322	22.839	N/A	0.892	0.891
2	364	2.374	23.481	0.892	N/A	0.913
3	361	2.348	23.158	0.891	0.913	N/A

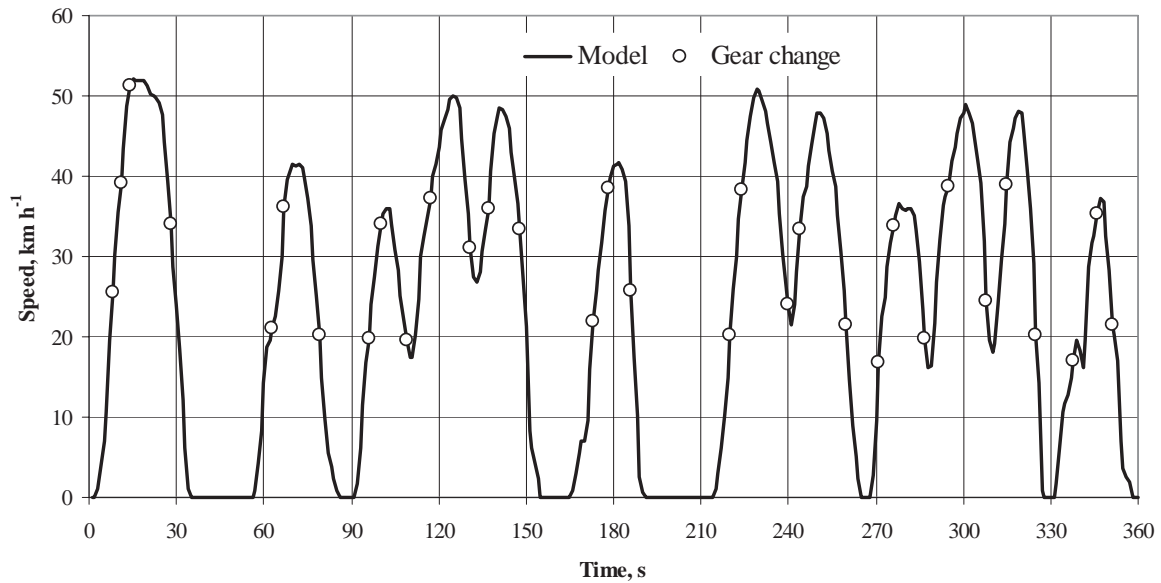

Figure 7. The model velocity curves and gear changing points.

The characteristics of the cycle match the overall summary characteristics of the data up to 97%.

Since the Mustang Software interface and menu does not provide a new driving cycle adding, then the system software core was investigated, variables were identified,

and the current cycle parameter files were analyzed, but self-made cycle was programmed. Its fragments are given in Table 2, but the appearance of the developed cycle in the test mode is shown in Figure 8.

Table 2

Program code fragments

Cycle general information	Speed points	Gear switching points
[General]	[SpeedPoints]	[ShiftPoint1]
Name=Jelgava	Point1 = 0	TimeIntoTest=8
RunningTime=360	Point2 = 0	FromGear=1
MaxSpeedToShow=60	Point3 = 0.7	ToGear=2
SpeedErrorLimit=2	Point4 = 2.5	[ShiftPoint2]
SpeedErrorTimeRange=1	Point5 = 4.4	TimeIntoTest=11
WarningToViolationTime=2	Point6 = 6.6	FromGear=2
MaxDistanceError=0.05	Point7 = 12.2	ToGear=3
HPIntegrationWindow1Start=55	Point8 = 15.8	[ShiftPoint3]
HPIntegrationWindow1End=81	Point9 = 18.8	TimeIntoTest=14
HPIntegrationWindow1Tolerance=0.5	Point10 = 22.1	FromGear=3
HPIntegrationWindow2Start=189	Point11 = 24.3	ToGear=4
HPIntegrationWindow2End=201
HPIntegrationWindow2Tolerance=0.5
LR_MinSE=0
LR_MaxSE=2	Point352 = 12.6	...
LR_Minm=0.96	Point353 = 10.6	[ShiftPoint31]
LR_Maxm=1.01	Point354 = 4.4	TimeIntoTest=346
LR_MinR2=0.97	Point355 = 2.3	FromGear=2
LR_MaxR2=1	Point356 = 1.6	ToGear=3
LR_Minb=-2	Point357 = 1.2	[ShiftPoint32]
LR_Maxb=2	Point358 = 0	TimeIntoTest=351
MaxISEPercent=1	Point359 = 0	FromGear=0
MinPurgeFlow=1	Point360 = 0	ToGear=0

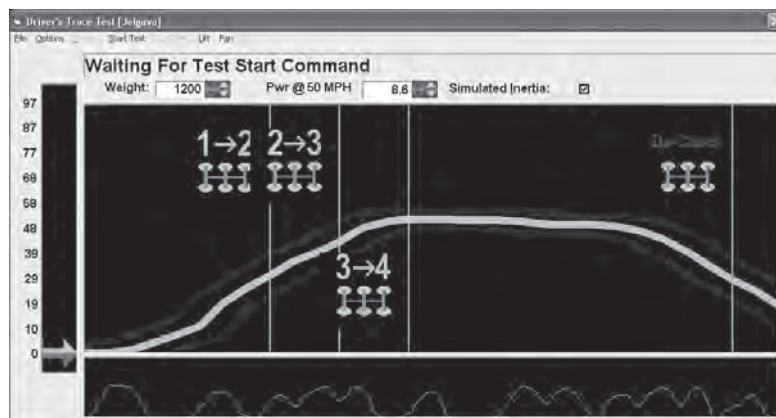

Figure 8. The appearance of the developed cycle in the test mode.

Results and Discussion

To determine whether a model (developed cycle) corresponds to the actual city driving, six test repetitions

were made on the chassis dynamometer. The results are summarized in Table 3.

Table 3

Model quality verification results (using biodiesel)

Parameters	Real driving tests	Laboratory tests	Difference, %
Distance, km	2.348	2.321	1.15
Average speed, km h ⁻¹	23.159	23.278	0.51
Average fuel consumption per 100 km, l	10.653	10.589	0.60

These results qualify as a high rating. To verify the fuel type influence on the model, the test series using the same

car, but different fuel were performed. The measurement and calculation results are given in Table 4.

Table 4

Model quality verification results (using fossil diesel)

Parameters	Real driving tests	Laboratory tests	Difference, %
Distance, km	2.362	2.331	1.31
Average speed, km h ⁻¹	23.356	23.332	0.10
Average fuel consumption per 100 km, l	9.666	9.584	0.85

Also in this case, the coincidence is very high. By analogy determining the quality of the cycle was also carried out with two other cars – Chrysler Voyager 2.5 CDI and Audi A4 (1.8 l gasoline engine), as it was necessary to be sure that the use of larger capacity diesel or petrol car does not influence the results. In all experiments, average fuel consumption differences between the real and bench driving did not exceed 1%.

By analogy with the methods described above, cycles for the second and third route, given in Figure 4, were developed. The length of the second route was 6.32 km, average speed – 29.67 km h⁻¹. For the third these parameters were correspondingly 17.47 km and 38.27 km h⁻¹.

Performing several repetitions of these routes, it was found that the larger is the distance the greater is also

the probability of various random factors (such as traffic light changes, pedestrian crossings, etc.). In these routes there was greater displacement of individual trip speed curves, but, thanks to the large route length, casual factor impact on the travelling time, average speed and fuel consumption was insignificant. Comparing the results of the real and bench driving, the differences were even smaller than in the urban core. Unfortunately, a direct imitation of such a long route on the bench relates with the high time consumption and the car ‘torture’. That is why further research will be carried out analysing phases of different trips (not just in Jelgava, but also in other cities). The trip data will be summarized by the following criteria: average speed of the entire driving cycle; average running speed; average acceleration; average deceleration; average micro-trip duration; time

proportions of driving modes for idling, acceleration and deceleration; and average number of acceleration-deceleration changes.

Summarizing the distribution of the various real-world driving routes parameters in different cities, the cycles for Riga, large and small cities will be created.

Conclusions

1. Development of the particular city urban driving cycles allows obtaining much more accurate and relevant data on the car's fuel consumption and harmful exhaust emissions than the use of standard cycles elaborated for vehicles certification.
2. In order to objectively simulate driving in the cities of Latvia, at least three different cycles have to be worked out, which would reflect the average traffic conditions of the city categories defined by the citizen population, street networks, and the existence of traffic lights.
3. Creating the capital and the largest city driving cycles, the road network has to be divided into three regions – the centre or core, and the two expanded areas. For each of these areas it is necessary to create independent cycles. For the particular city core analysis, best fits direct imitation of the real driving route, but for the expanded areas – modal or polygonal cycles.
4. Analyzing the software data modules of chassis dynamometer, it is possible to program own cycles that correspond to the particular circumstances of the city.
5. For the first cycle developed for Jelgava, the model quality was determined using vehicle driving parameters and fuel consumption measurement results from both the road and laboratory tests. Since the obtained data coincidence of all the parameters exceeded 98%, the elaborated cycles can be used for the biofuel efficiency determination in car tests.
6. Performing further studies, other cities data and traffic conditions have to be collected and analysed. Based on these analyses, uniform driving cycles can be developed reflecting overall real driving routes of Latvia.

References

1. Andre M., Joumard R., Vidon R., Tassel P., Perret P. (2006) Real-world European driving cycles, for measuring pollutant emissions from high - and low-powered cars. *Atmospheric Environment*, No 40, pp. 5944-5953.
2. Emission Test Cycles. Summary of worldwide engine and vehicle test cycles. (2008) Available at: <http://www.dieselnet.com/standards/cycles/>, 19.03.2009.
3. Esteves-Booth A., Muneer T., Kirby H., Kubie J., Hunter J. (2001) The measurement of vehicular driving cycle within the city of Edinburgh. *Transportation Research Part D*, pp. 209-220.
4. European Regional and Urban Statistics. Reference Guide. (2007) EUROSTAT Methodologies and working papers. Luxembourg: Office for Official Publications of the European Communities, ISSN 1977-0375, 261 p.
5. Hung W.T., Tong H.Y., Lee C.P., Ha K., Pao L.Y. (2007) Development of a practical driving cycle construction methodology: A case study in Hong Kong. *Transportation Research Part D*, pp. 115-128.
6. Kuhler M., Karsten D. (1978) Improved driving cycle for testing automotive exhaust emissions. SAE Paper 780650, Warrendale, pp. 119-132.
7. Lin J., Niemeier D.A. (2002) An exploratory analysis comparing a stochastic driving cycle to California's regulatory cycle. *Atmospheric Environment*, No 36, pp. 5759-5770.
8. Tzirakis E., Pitsas K., Zannikos F., Stournas S. (2006) Vehicle emissions and driving cycles: comparison of the Athens driving cycle (ADC) with ECE-15 and European driving cycle (EDC). *Global NEST Journal*, Vol 8, No 3, pp. 282-290.